

## BASE-METAL THERMOCOUPLE ASSEMBLIES

The base-metal thermocouple covers the majority of applications within industry over a range of -80°C to +1300°C.

<b>Type T</b>	<b>Copper Constantan</b>	<b>-180°C to +400°C</b>
<b>Type J</b>	<b>Iron Constantan</b>	<b>0°C to +750°C</b>
<b>Type E</b>	<b>Chromel® Constantan</b>	<b>0°C to +900°C</b>
<b>Type K</b>	<b>Chromel® Almel®</b>	<b>0°C to +1200°C</b>
<b>Type N</b>	<b>Nicrosil Nisil</b>	<b>0°C to +1300 °C</b>

The base-metal element is available in two basic forms: (1) Bare Wire and Beads, and (2) Mineral insulated. (Details are on separate sheet called *Mineral insulated thermocouples*). The bare wire and bead construction normally requires additional protection from the medium being measured. The mineral insulated system, however, can be used on its own, except in particularly severe conditions, such as in aluminium or brass foundries.

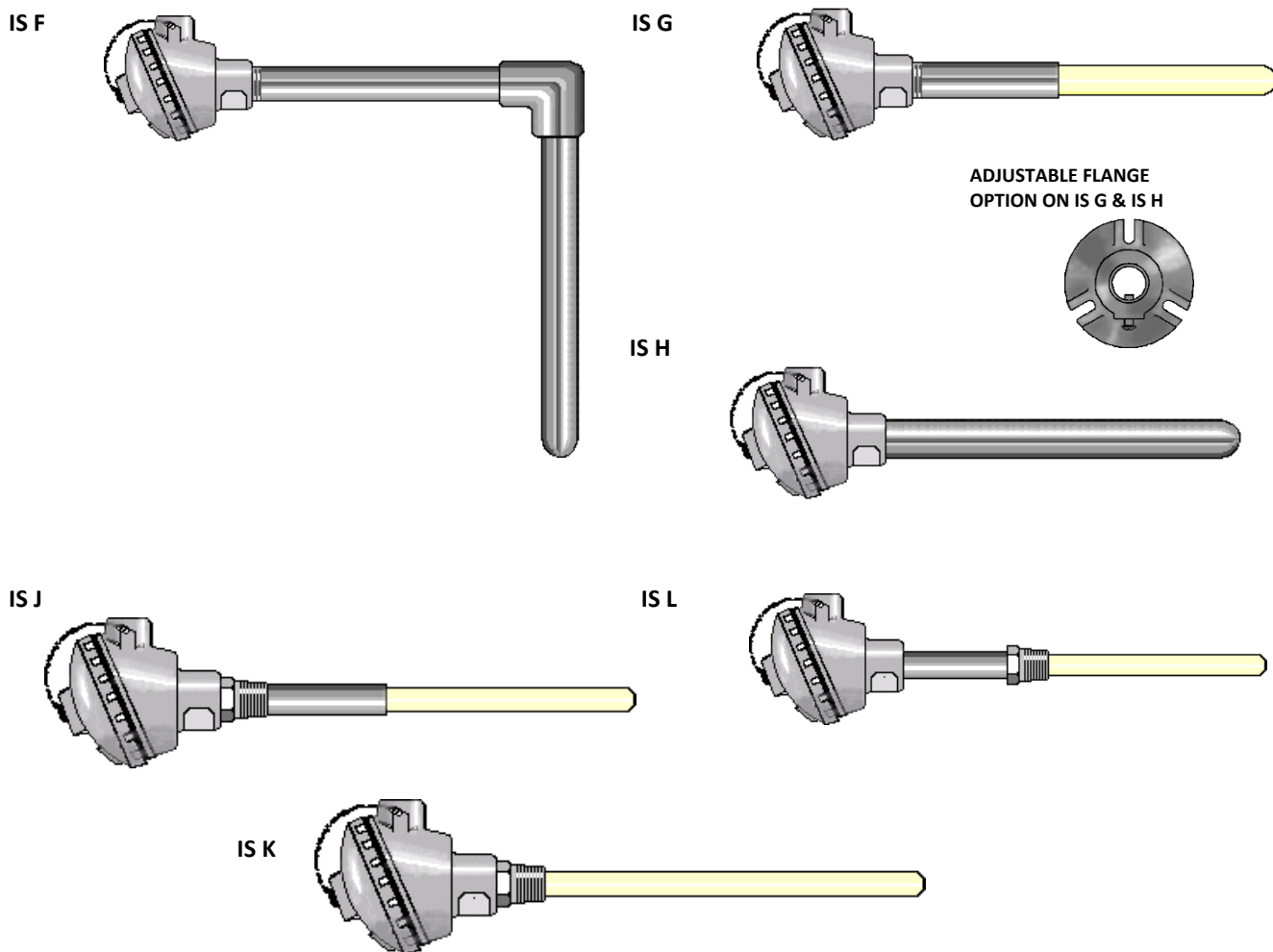

A.B.N. 32 001 378 070

[www.pyrosales.com.au](http://www.pyrosales.com.au)

**SPECIAL PROTECTION SHEATHS**



**SERIES 1100**



**METAL CERAMIC**



**METAL – AVAILABLE IN MOST  
PIPE MATERIAL GRADES**



**HEXOLOY® / SYALON®**



**SILICON CARBIDE**



**CERAMIC COATED CAST IRON**

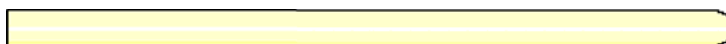

**RECRYSTALISED ALUMINA**

**PROTECTION SHEATHS**

Type	Code	Recommended Max. Temp	Remarks
316 SS	316	870°C	Good corrosion resistance
446 SS	446	1090°C	For use where sulphur is present
INCONEL 600/601	600/601	1150°C	Not to be used where sulphur is present
253 MA	253	1100°C	Economical replacement for Inconel 600
Metal Ceramic	LT-1	1370°C	Used in copper, brass and steel industries
Plumbago	VG	1350°C	Used in brass foundries
Silicon carbide	SIC	1650°C	Used in aluminium industry
Aluminous porcelain	IAP	1500°C	General purpose furnace applications
Coated 1100 series	1100	1160°C	Used in aluminium industry
Hexoloy®	HEX	1650°C	Most corrosive / erosive environments
Syalon®	SY	1150°C	Used in aluminium industry

The recommended sheath temperature is limited by the thermocouple range. For higher temperatures refer *Rare Metal* thermocouple data sheets.

The above only cover the most commonly supplied thermocouples. We specialise in ‘Made to Order’ units, and will quote against your specifications.

- Hexoloy® Registered trade mark of Carborundum Company.
- Syalon® Registered trade mark of Cookson.
- Chromel® Registered trade mark of Hoskins Manufacturing.
- Alumel® Registered trade mark of Hoskins Manufacturing.