

EL50 is an economic digital IR Pyrometer from E series with extended sensing head in 4 wire technology for non-contact temperature measurement between -20°C to 800°C. The sensor head is unaffected by electromagnetic interferences. The pyrometers are specially designed in a such way that sensor head can withstand ambient temperature upto 120°C easily.

The pyrometer is equipped with a Inbuilt 4 digit LCD display which offers many signal processing features. The electronic box with integrated Keypad helps in setting parameters like Emissivity, Analog Sub range, Set point, Hysteresis (Hyst), Analog Output, Unit of temp(°C or F), Response Time, Peak Picker and Sensor address etc.

EL50 is provided with USB 2.0 output and PC software. The pyrometer can be powered through USB port. In this case no external power supply is required. 24 VDC is required for operation of Analog Output, RS-232 & RS-485 & Relay Output. Analog output is 4...20mA, 0...20mA, 0...10V, Thermocouple type "K" or "J" (userselectable) via keypad or software. RS-232/RS-485 Serial interface card is available as optional.



Technical Specifications

| Model | EL50 |
|--|---|
| Temperature Range (Analog sub-range adjustable) | -20° - 800°C |
| Spectral Range | 8...14 μm |
| Photodetector Type | Thermopile |
| Distance to Spot Size Ratio | 2:1 (To be specified while ordering) 15:1 |
| Emissivity (ε) | 0.1...1.2 adjustable |
| Response Time | 20 msec adjustable upto 10 sec |
| Accuracy | ± 1% of the measured value or 3°C whichever value is greater (The sensor head must be at constant ambient temperature for a minimum of 15 minutes) |
| Repeatability | 0.3% of reading in °C + 1°C |
| Analog Output | 0-20mA, 4-20mA, 0-10V, Thermocouple Type "K" or "J" (User selectable) |
| Digital Output | USB 2.0 RS-232/RS-485 interface card (Optional) *At a time only one digital output possible |
| Operating Temp. Range | Electronic Box upto -20°C to 70°C Sensor head upto 120°C |
| Storage Temp. Range | -20°C...70°C |
| Relay Output | Relay Output with hysteresis 60V DC/42V AC RMS, 0.4A |
| Adjustable Parameters and Features via Software | Emissivity, Response Time, Clear Time (Peak Picker), Analog Output, Sub Range, Unit Of Temperature (°C/°F), Communication mode(Comm.mode), Record feature etc. |
| Adjustable Parameters and Features via Keypad | Emissivity, Setpoint, Hysteresis (Hyst), Analog Sub Range, Analog Output, Unit of temperature, Sensor address, Response Time, Clear Time (Peak Picker) etc. |
| Power Supply | 12V to 28V DC with reverse polarity protection |
| Power Consumption | Max 2.5 watt |
| Protection Class | IP65 |
| Housing | Sensor head-Stainless Steel; Electronic Box: Zinc Power supply, *Digital output and Analog output are galvanically isolated against each other * Not applicable for USB 2.0 digital output |
| Isolation | |
| Operating Humidity | 10-95%, Non-Condensing Conditions |
| Weight & Dimensions | 600g, 112.5mm x 82.5mm x 33mm (L x W x H) |

Features

- Power Supply (12V to 28V DC with reverse polarity protection)
- Sensor head withstands ambient temperature upto 120°C
- Spectral range 8 μm...14 μm
- Wide temperature ranges (-20°C to 800°C)
- Inbuilt LCD Display and Keypad for parameterisation
- Fast response time within milliseconds
- Analog output 4...20mA, 0...20mA, 0...10V, Thermocouple type "K" or "J" (user selectable)
- USB 2.0 Digital output
- RS-232/RS-485 Serial interface card
- Relay output
- User friendly PC software for communication

Standard Scope of Supply

- Pyrometer with LCD Display
- Keypad for parameterizing
- Extended Sensor head with 3 mtr cable
- Analog output like 4...20mA, 0...20mA, 0...10V, Thermocouple type "K" or "J" (user selectable)
- USB2.0 Digital output, USB Cable
- Relay Output
- Calibration certificate, Software & Operation manual

Optional

- Mechanical and Electrical Accessories
- RS-232 / RS-485 interface card
- Extra Sensor Head Extension Cable Lengths

Applications

- Plastic,
- Rubber
- Ceramic
- Paper
- Textile
- Fluids
- Oxide/Painted metal surface
- Wood and Glass Industries

Software "Infrasoft"

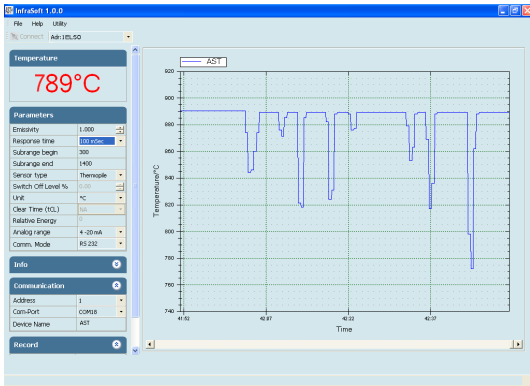

Spot Sizes

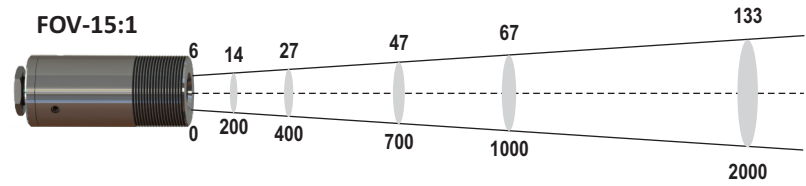

Pyrometer Drawing

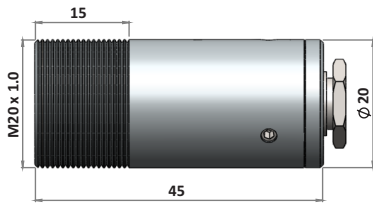

Sensing Head

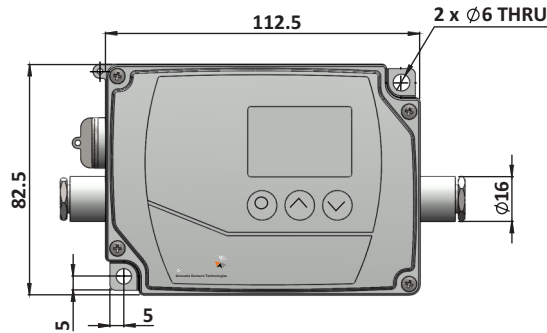

Electronics



Accessories

Air Purge Unit For Sensor Head
(Reference No. - 8300-03)

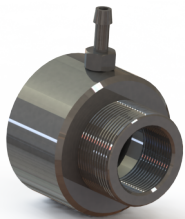

Adjustable Mounting for Sensor Head
(Reference No. - 8300-04)



Converter RS-232 ↔ RS-485
(Reference no: 9000-03)



Power supply Input 110/230V AC
Output 24 V DC, 0.7Amp.
(Reference No. 9000 - 02)



Accurate Sensors Technologies Pvt. Ltd.
Misgav Industrial Park, Misgav 20174 Israel
Phone : +972-4-9990025, Fax : +972-4-9990031
E-mail : info@accuratesensors.com

Accurate Sensing Technologies Pvt. Ltd.
188A, B-169 (Part), B-188 (A), Road No. - 5, M. I. A.,
Madri, Udaipur (Rajasthan) - 313003
Phone : +91-294-3507736, Fax : +91-294-3507731
Email : sales@accuratesensors.com

AST
Accurate Sensors Technologies

EL50-H is a digital Pyrometer in economic range with extended sensor head in 4 wire technology, for non-contact temperature measurement between 0°C to 800°C. The sensor head is unaffected by electromagnetic interferences. The pyrometer sensor head is specially designed to withstand ambient temperature upto 180°C without cooling.

The pyrometer is equipped with a Inbuilt 4 digit LCD display which offers many signal processing features. The electronic box with integrated Keypad helps in setting parameters like Emissivity, Analog Sub range, Set point, Hysteresis (Hyst), Analog Output, Unit of temp (°C or F), Response Time, Peak Picker and Sensor address etc. Analog outputs options available are 4...20mA, 0...20mA, 0...10V, Thermocouple type "K" or "J" (userselectable) via keypad or software. RS-232/RS-485 serial interface card is available as optional.

EL50-H is provided with USB 2.0 output and PC software. The pyrometer can be powered through USB port. In this case no external power supply is required. 24 V DC is required for operation of Analog Output, RS - 232 & RS - 485 & Relay Output.

Technical Specifications

| Model | EL50-H |
|---|--|
| Temperature Range(Analog sub-range adjustable) | 0°C...800°C |
| Spectral Range | 8...14 μm |
| Photodetector Type | Thermopile |
| Distance to Spot Size Ratio | 2:1 15:1 (To be specified while ordering) |
| Emissivity (ε) | 0.1...1.2 adjustable |
| Response Time | 60 msec adjustable upto 10 sec |
| Accuracy | ±1.5% of the measured value or 3°C whichever is greater (The sensor head must be at constant ambient temperature for a minimum of 15 minutes) |
| Repeatability | 0.3% of reading in °C + 1°C |
| Analog Output | 0-20mA, 4-20mA, 0-10V, Thermocouple Type "K" or "J" (User selectable) |
| Digital Output | USB 2.0 RS-232/RS-485 interface card (Optional) *At a time only one digital output possible |
| Operating Temp. Range | Electronic box upto 70°C Sensor head upto 180°C |
| Storage Temp. Range | -20°C...70°C |
| Relay Output | Relay Output with hysteresis 60V DC/42V AC RMS, 0.4A |
| Adjustable Parameters and Features via Software | Emissivity, Response Time, Clear Time (Peak Picker), Analog Output, Analog Scale (Sub Range), Unit Of Temperature (°C/°F), Communication mode(Comm. mode), Record feature etc. |
| Adjustable Parameters and Features via Keypad | Emissivity, Setpoint, Hysteresis (Hyst), Analog Sub Range, Analog Output, Unit of temperature, Sensor address, Response Time, Clear Time(Peak Picker) etc. |
| Power Supply | 12V DC to 28 V DC with reverse polarity protection |
| Power Consumption | Max 2.5 watt |
| Protection Class | IP65 |
| Housing | Sensor head-Stainless Steel; Electronic Box : Zinc |
| Isolation | Power supply, *Digital output and Analog output are galvanically isolated against each other * Not applicable for USB 2.0 digital output |
| Operating Humidity | 10-95%, non condensing conditions |
| Weight & Dimensions | 600g 112.5mmx82.5mmx33mm(L x W x H) |



Features

- Power supply (12V DC to 28 V DC) with reverse polarity protection
- Sensor head can withstand ambient temperature upto 180°C
- Spectral range 8 μm...14 μm
- Wide temperature ranges (0°C to 800°C)
- Inbuilt LCD Display and Keypad for parameterisation
- Fast response time within milliseconds
- Analog output like 4...20mA, 0...20mA, 0...10V, Thermocouple type "K" or "J" (user selectable)
- USB2.0 Digital output and RS-232/RS-485 Serial interface card
- Relay output
- User friendly PC software for communication

Standard Scope of Supply

- Pyrometer with LCD Display
- Keypad for parameterizing,
- Extended sensor head with 3m cable
- USB 2.0 Digital output, USB Cable
- Relay Output
- Analog output 4...20mA, 0...20mA, 0...10V, Thermocouple Type "K" or "J" (user selectable)
- Calibration certificate, Software & operation manual

Optional

- Mechanical and Electrical Accessories
- RS-232 & RS-485 serial interface card
- Extra Cable Lengths

Applications

- Plastic, Rubber & Ceramic
- Paper
- Textile
- Fluids
- Oxide/Painted metal surface,
- Wood and Glass Industries

Software "Infrasoft"

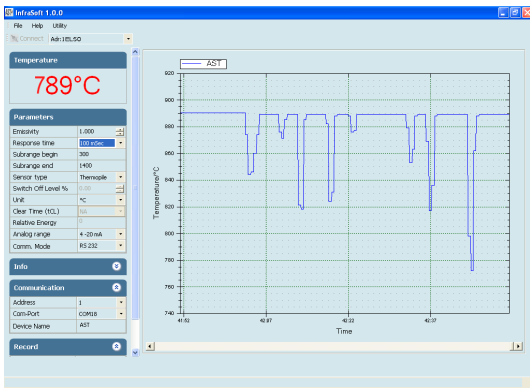

Spot Sizes

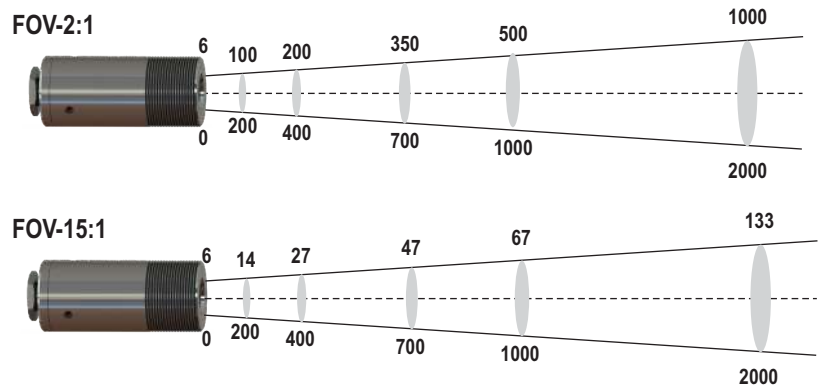

*All Dimensions are in "mm".

Pyrometer Drawing

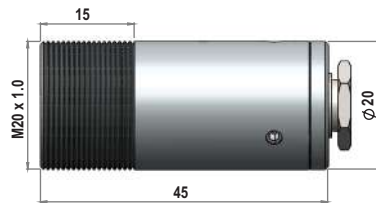

Sensing Head

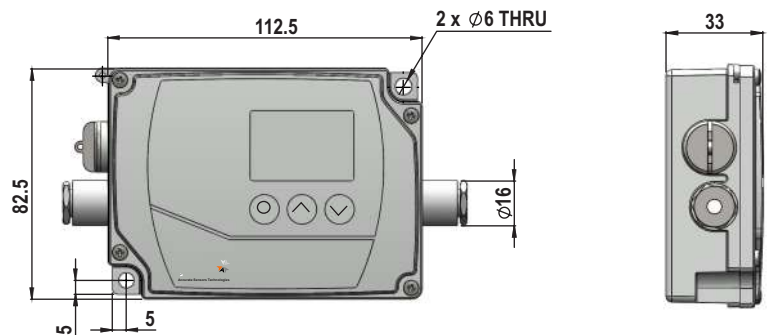

Electronics

Accessories

Air Purge Unit For Sensor Head
(Reference No. - 8300-03)



Adjustable Mounting for Sensor Head
(Reference No. - 8300-04)



Converter RS-232 ↔ RS-485
(Reference no: 9000-03)



Power Supply Unit
(Reference no: 9000-02)



AST

Accurate Sensors Technologies

Misgav Industrial Park, Misgav 20174 Israel
Ph. : +972-4-9990025, Fax : +972-4-9990031
E-mail : info@accuratesensors.com
www.accuratesensors.com



We measure accurate temperature in extreme conditions